

A Biologically Inspired Approach for the Control of the Hand

Emmanouil Hourdakis, Michail Maniadakis and Panos Trahanias

Abstract-The control of the hand in primate species is characterized by a high dimensionality, due to the large number of joints in the fingers. In this study we present how its manipulation can be simplified without compromising its usage, through a constraint methodology that is inspired from recent neurobiological findings. We further develop a computational model, consisting of several brain areas related to hand control, using a co-evolutionary architecture. Due to its neurobiological basis the methodology gives rise to a number of emergent properties that have been shown to occur in primate species during reach-to-grasp tasks.

I. INTRODUCTION

In biologically inspired robotic motion control, reaching-to-grasp tasks are considered quite interesting, due to the diverge roles of the collaborating brain regions that are involved in their execution, as well as the high dimensionality that is imposed by the large number of joints in the articulator. Since the variety of tasks that we perform using our hands, is characterized by different levels of detail, controlling such complex apparatus in an exhaustive manner, i.e. explicitly move each joint individually, seems rather redundant. Recent studies in neurobiology indicate that our brain has evolved to resolve the ambiguity of each task, and initiate different levels of control for the hand, which are in turn processed on interdisciplinary brain regions. Apart from the traditional motor related neurons in the primary motor cortex, these studies indicate the contribution of supplementary brain areas, such as the Somatosensory (SI, SII) and Spinal Cord (Sp), to motor control. More importantly, they indicate the manipulation of the hand as being the product of different resolution levels, each partially contributing to the final motion.

Most of the interrelated research in the field has focused on directly solving the problem, using Hebbian learning rules on architectures of Neural Networks, and relying on the pre-tuning of the dividing linkages to resolve the

complexity of the problem. The complication of the hand was either confronted implicitly by custom Neural Networks, or explicitly through constraint models that were designed for specific tasks. Here we present a biologically inspired computational model that is based on experimental studies indicating the hand being controlled on different resolution levels during action execution. These simplifications are imposed by several brain areas in the form of kinetic coordination patterns, on a peripheral, i.e. global force control level, as well as local, i.e. fine-tuning, perspective. Our approach contrasts previous endeavors in the field, since it deals with the problem implicitly through the defining roles of the brain. The strength of our model is evident in numerous control strategies that are evolved during various experiments, which present a strong resemblance with the ones employed by nature.

Among the most noticeable computational models in the field, is the FARS architecture [1] which replicated the roles of several brain areas, by pre-tuning cell activations to perform reaching tasks, without assuming any specific hand-model. Oztop and Arbib [2] later endowed that architecture with the computational counterparts of the pre-motor (PM) and primary motor cortex (M1) to study imitation of grasping. The large degree of variability of the joints was confronted through an empirical constraint model that would simplify the control of the articulator, using task-related parameters such as the distance of the fingers to the object, or the disparity axis between the hand and the object. More recently other projects employed Hebbian Neural Networks to create a model that could benefit from self-observation [3] or from watching a human [4] in order to develop an adequate controller for imitation of grasping. Most of these studies employ the concept of mirror neurons [5], which indicates overlapping activations in the F5m area of the pre-motor cortex during execution and observation of primates. Due to the mirror neuron hypothesis, the main functioning of the control task in these models was either focused directly on the F5m region, or neighboring areas, leaving any remaining parts to carry out sensory processing tasks. More recently, brain imaging methods such as C-Deoxyglucose, that provide a greater resolution on the internal activations of the motor control related brain regions, indicate that these overlapping execution/observation activations occur over a wider spectrum [6] of cortical areas. These findings indicate the importance of additional brain regions that collaborate and contribute to the control of the hand, among which the Somatosensory cortex. Even though this study is not mainly concerned with imitation, the underlying areas that are being activated during the execution of a behavior resemble at a great extent the ones being active during imitation. Further neurobiological studies [7] have reported that the processing

Manolis Hourdakis is a PhD student with the Department of Computer Science, University of Crete, Greece, and has a scholarship from the Computational Vision and Robotics Laboratory, Institute of Computer Science, Foundation for Research and Technology - Hellas, Heraklion, Greece (e-mail: ehourdak@ics.forth.gr)

Michail Maniadakis is a postdoctoral researcher with the Computational Vision and Robotics Laboratory, Institute of Computer Science, Foundation for Research and Technology - Hellas, Heraklion, Greece (e-mail: mmaniada@ics.forth.gr)

Panos Trahanias is a Professor with the Department of Computer Science, University of Crete, Greece, and the Head of the Computational Vision and Robotics Laboratory, Institute of Computer Science, Foundation for Research and Technology- Hellas, Heraklion, Greece (e-mail: trahania@ics.forth.gr).

The work presented in this paper has been partly supported by the European Commission funded project MATHESIS, under contract IST-027574

of the hand control occurs in diverge levels and resolutions, and is distributed among several areas in the brain. Another characteristic of hand control is that even though grasping tasks are commonly complex in nature, most of their motion can be described by a small number of standard postures. Masson [8], using Principal Component Analysis on recorded trajectories of Macaque monkeys while performing a grasp task, illustrated that the complete motion of a power grab can be reproduced adequately using only a few standard postures (named eigenpostures).

It is rather obvious that a constraint model for the simplification of the hand is necessary, but it should be coupled with the ability to initiate solitary finger motion (a.k.a. single-digit control). In Macaque monkeys it has been shown that the reduced ability to individuate the motion of single fingers, has resulted in performing an abridged variety of grasps [9].

Thus, a key issue that rises is to impose such constraints on the synergies of the hand in a way that will complement and extend its applications and usability, rather than bound them. In addition, the constraint model that will be used should be general enough to cover the great variety of tasks that are performed using the hand. A good example of constraints is the Hand-state hypothesis [2] a simplification model for the hand, that was based on the virtual fingers theory [10]. The main intuition behind this is that fingers consist as physical entities and are characterized by their contact surfaces. Hand state was then brought as an extension to this concept, and suggested that the grip controller should process task specific parameters, instead of explicitly controlling all joint parts of the hand. Even though this approach seems promising when dealing with the high complexity imposed by the joints, the method is based on empirical observations derived from the specific grasp tasks under study. In addition, their constraint model is decoupled from the computational model, leaving any processing solely on the outputs of the underlying Neural Networks, while the hand model is fed externally any control commands.

II. BIOLOGICALLY INSPIRED GRASPING

Our approach to grasping is based solely on neurobiological experiments, revealing what types of simplifications are employed by primate species in order to control their palm and fingers. More importantly, we do not make any compromises on the structure of the hand, but rather focus on defining roles for various brain regions in order to control different combinations of joints at different resolution levels. This is mainly derived from evidence, showing that such constraints do exist in primate species, and are imposed through the functioning of particular brain regions. More specifically, recent evidence indicate that the 27-DoF of joints existent in the hand are controlled both in a global level, i.e. a universal, common to all joints, force navigates the fingers to complete the assignment intended, and in a local level, where fine-tuning initiatives, on

individual fingers, are taken to increase the performance on a particular task [7]. In addition, it has been shown that the pre-shaping of the posture occurs long before the fingers come in contact with the object, still while the hand reaches towards the objective position, where fingers gradually take a formation to approximate the object contour [11]. Variance of the grasp tasks is then attained by acting forces explicitly on specific fingers, after touching the object. These coordination patterns have been shown to hold more than 90% of the discrepancy in grasping tasks [8], while the remaining 10% is handled through individual motion, custom to the specifics of the action being performed. The same study also reports, that a small number of these coordination patterns is adequate for reproducing a complete grasp motion, which also seem to be organized along a gradient from lower to higher finger movement individuation. Therefore the higher principal components reported in the analysis of [8], encapsulate the coordination patterns that pre-shape the hand to an approximation of the object contour, while the remaining perform fine adjustments on the hand shape.

III. A MODEL FOR GRASPING

As mentioned during the introduction, our approach does not impose any sort of constraints to the articulator itself, but rather on the way it is controlled. Our proposed model therefore, in accordance to biology, is concerned with providing an underlying control framework for the forces that are applied on the joints of the fingers of our robot, on two different resolution levels, at a global level, to perform an initial shaping of the hand, and on local level, in order to fine-tune the posture, as illustrated by Fig. 1. More specifically each junction between fingers in our model is controlled by four force inputs, two that control each joint individually and two that control all joints, through a global force. Two neurons refer to each joint, and are assigned the roles of controlling the flexor and extensor muscles as suggested by neurobiological studies (the flexor is responsible for the positive force applied between two body part junctions, while the extensor refers to the negative one. The sum of the flexor and extensor corresponds to the final force that is applied to the joint). The two remaining neurons impose a general force level that is applicable on all body parts, using also this flexor/extensor intuition. The degree to which each neuron affects the final motion of the corresponding joint is also set as an open parameter, scaling the final outcome, between global and local force levels. Ideally this parameter should be fine-tuned to converge to an appropriate compromise between the two levels of resolution, in accordance to the requirements of the task in hand. Therefore, for tasks that require explicit control of individual joints the global assigning parameter should be set to a low value, in order to emit the effect of the general force during motion, and maximize individual finger movement. The remaining parts of the hand, corresponding to the main arm joints (elbow and shoulder), are assigned

only one pair of neurons per joint and thus are not affected by the global force parameter.

In our simulations, the hand is controlled by a computational model that replicates the operation of several cortical regions known to be active during primate hand control. In these experiments we have replicated the role of the F4 and F5

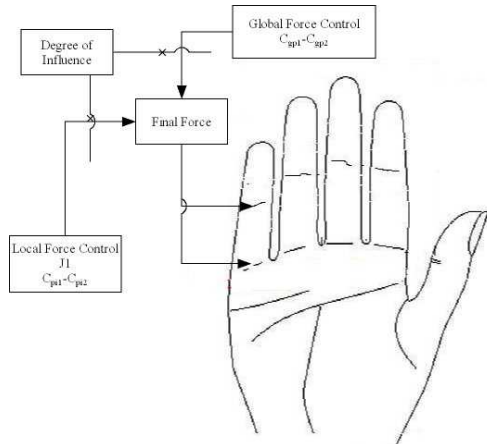

Fig. 1. The two control levels for the hand. Global force applies to all joints in the fingers, while local is specific to one joint. The degree of influence scales appropriately each level of control, and sends the final force command to the controller of the robot's hand.

areas of the pre-motor cortex, and the primary motor cortex (M1). Each brain area is assigned a different role (using a fitness function), in accordance to its biological counterpart. The complete representation of the computational model is illustrated in Fig. 2. The inputs to our system consist of the recurrent sensory signals emitted by the touch sensors in the fingers of our simulated robot, as well as the distance of the index finger from the object, which we calculated empirically, based on the space between the object and the hand (using the software of the simulator). We note here that the model does not process any shape specific parameters, such as the diameter of each item to be grasped, but instead approximates the appropriate posture based on an ad-hoc interaction with each object, through the perceived sensory indications from the fingers.

In our implementation, the F5 pre-motor cortex is evolved based on the ability of the fingers to form an appropriate posture in respect to the object present on the scene (evaluated by measuring the type and amount of contact made). In addition, the F4 region is evolved to optimize the performance of the joints that refer to the upper parts of the hand (two joints for the shoulder, one joint for the elbow) and thus corresponds to the reaching counterpart of the task.

Up till now, there was a strong ambiguity on the explicit role of the primary motor cortex to motor control. Most computational related studies have defined this area as a predecessor of the spinal cord, assigned the task to activate the motor neurons (e.g. [2, 12]). Our computational counterpart for the primary motor cortex is based on

neurobiological evidence [7] that denote its functionality as globally acting on the final commands based on the overall performance of the robot in the task.

All underlying processing occurs in the computational model, which encapsulates the brain of our robot, while the outputs are filtered externally using the following equation:

$$J_i = R_{li}(C_{pi1} - C_{pi2}) + R_g(C_{gp1} - C_{gp2}) \quad (1)$$

where J_i refers to the i^{th} joint of the hand, R_{li} is the local force level that controls the effect of the confined control inputs C_{pi1}, C_{pi2} to the task, while R_g is the extent to which the global force level inputs, C_{gp1}, C_{gp2} , influence motion, and are common to all joints. An important aspect of eq. 1 is that it does not define any relation between the global R_g and local R_{li} force levels. Even though the computational model could be assigning both of these variables individually, we believe it is a good practice to define a relation between them, in order to optimize the processing requirements of the task. In its most general form, this relation would have the following form:

$$R_l = f(R_g) \quad (2)$$

The most obvious definition for f would be to embody a percentage type function. Therefore, assuming that the outputs of the neurons range from 0 to 1 (sigmoid units):

$$f(x) = 1 - x \quad (3)$$

More elaborate tasks however could benefit from f using an inverse log function, therefore obliging complexity to remain low during the initial levels of control where the details of the task are usually unknown, and increasing gradually with time. A common function that encapsulates such gradual increase is the inverse log function:

$$f(x) = \log^{-1}(x) \quad (4)$$

An example where eq. 4 could provide a better output for the model is in a combined reaching and grasping task, where the grip is not in contact with the object during most of the time.

It is evident from the above, that the only constraints that are imposed to the model are of kinematic nature, i.e. kinetic coordination patterns, and not on the articulator itself. The strength of such model is that it facilitates both detailed and general motion control, relying on the underlying cognitive model to resolve the degree to which higher, and thus more complex (and detailed), or lower resolution is required. In addition, the constraint methodology works in cooperation with the computational model, by allowing modifications on the scaling parameter between the two control levels, instead of acting on a top level. Later in this paper, we demonstrate how our model is able to resolve the level of difficulty of each task, and innately assign a global force level scale

factor that matches its ambiguity, using solely the feedback from the Somatosensory.

IV. CO-EVOLUTIONARY MODEL

It is evident from the description above, that our proposed methodology for grasping does not make any assumptions on the underlying cognitive model that should be used. This grants the methodology with generality, as it is possible to be combined with any implementation of a computational model. In a previous work [13], we demonstrated how a co-evolutionary framework [14] is able to tune the interconnectivity of several Neural Networks to perform reaching tasks. In this study, we extend this model to include our grasping prototype in the architecture, and evaluate the overall performance in grasping related experiments. In addition to our previous work, we also specify each Neural Network in our model with a defining role to the control process. The intuition behind our co-evolutionary modelling approach is that several co-evolving populations of Neural Networks are used to optimize a diverse range of brain regions which are assigned different fitness functions, while the architecture as a whole is attempting to accomplish a specific task. Each Neural Network in the architecture corresponds to a specific brain area, and is evolved based on a fitness function that encapsulates the computational specifics of its biological equivalent. For more details on the implementation of the co-evolutionary brain modelling approach, the interested reader is referred to [14].

V. EXPERIMENTS

We employed the Webots simulation platform, a commercial 3D physics package that included an accurate replication of the Fujitsu Hoap2 robot. To perform the experiments, we extended the simulator, to three fingers, thumb-middle-index, each consisting of two 2DoF joints, for each of the lower and upper finger parts, attached to a wrist of 3DoF. The control of the articulator depended on the outputs of the co-evolutionary architecture, consisting of five interconnected levels of Neural Networks, with membrane potential neurons. Each level was explicitly assigned a fitness function that corresponded to its biological counterpart, and awarded the evolved individuals that performed adequately on trial tasks. The final network included 21 sigmoid outputs that acted as input to the constraint model. The complete representation of our system is shown in Fig. 2.

The level corresponding to the F4 area of the pre-motor cortex was assigned the role of evaluating the performance of reaching tasks. The fitness function that was used to evaluate the region is the following:

$$F4_{Fitness} = \frac{1}{D_{OT}} \quad (5)$$

where D_{OT} is the distance between the thumb and the object. Therefore, the $F4_{Fitness}$ function evaluated the degree to which a specific motor initiative resulted in the palm advancing towards the object. This assumption is in accordance to neurobiological studies that indicate F4 to be associated with motor controls that result in reaching of the whole hand towards the object.

The area that encapsulated the F5 pre-motor cortex inputted only the sensory information that was recurrently fed from the Somatosensory cortex (i.e. the touch sensors in the fingers of our robot). Based on the definition of a power grab, the fitness function of the pre-motor region was set to benefit the individuals in the population that achieved maximum contact with the object for the most time.

$$F5_{Fitness, Power\ Grab} = \sum_{t=1}^n \sum_{i=1}^F Cn_{ti} \quad (6)$$

where t equals the time-steps for each task, F the number of body parts in the hand (two parts for each of the three fingers) and Cn_{ti} a Boolean variable indicating whether the specific part was in contact with the object during the t step. Therefore eq. 6 sums the contact made by all fingers, over all the time steps of each task.

The second task evaluated the ability of the controller to perform a precision grip. For this reason we modified the fitness function to penalize any contact made by the lower parts of the fingers, while benefit individuals that resulted in contact of the object with the upper parts. The fitness function used in this case is shown below:

$$F5_{Fitness, Precision\ Grip} = \sum_{t=1}^n \sum_{j=1}^{F_U} Cn_{tj} - \sum_{t=1}^n \sum_{i=1}^{F_L} Cn_{ti} \quad (7)$$

where the first term corresponds to the sum of time steps that all the upper parts, of all the fingers (F_U) were in contact with the object, while the second sums time steps in contact with all the lower finger parts (F_L). Ideally this fitness function should result in the robot moving only the upper parts of its fingers, keeping the lower ones immobile.

We point out, that the last two fitness functions (in eqs. 6,7), which are assigned to F5, are independent of the specifics of the object to be grasped, i.e. no information on the contour of the object is forward to the computational model. Instead, we use the degree to which the controller performed appropriately a grasp, which is depicted in the number of time steps specific fingers were in contact with the object. This is in accordance to neurobiological studies which indicate that a large degree of the shaping of the hand occurs during the initial levels of control, without processing the visual information of the object, but instead combining stored information regarding the task, and feedback

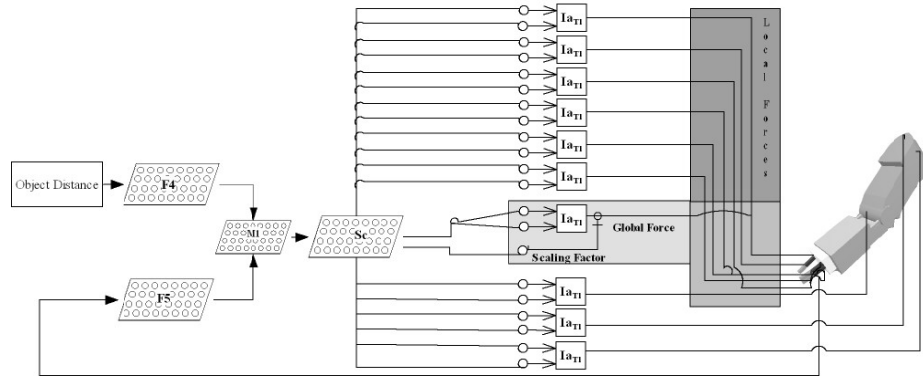

Fig. 2. The complete architecture of our system. On the left exists our co-evolutionary scheme that encapsulates the operations of F5, F4, M1, Sc brain regions. The constraint model is applied on the scaling between global and local force levels which is depicted on the connectivity of the outputs with the hand. The Ia regions, correspond to the flexor/extensor pairs for each joint.

that is received from the Somatosensory [7]. Our results demonstrate that the articulator can form an appropriate grasp posture, even without shape information. To the authors' knowledge, this is the first attempt to confront the problem of grasping using only information from the interaction of the object.

Finally, the top-level Neural Network, was assigned the role of the Primary motor cortex, i.e. evaluate the overall performance of the output, based on the two levels of motor coordination (reaching and grasping). Therefore the fitness function for this task was set to the product of all the previous fitness functions:

$$M1_{Fitness} = F4_{Fitness} * F5_{Fitness} \quad (8)$$

where $F4_{Fitness}$ is computed from eq. 5, and $F5_{Fitness}$ from either eq. 6 or 7, depending on the task we are testing.

Biological studies indicate the role of the spinal cord as to distribute the motor signals on the muscles of the body, i.e. the controllers in our robotic simulation. Due to this, the module equivalent to Spinal Cord consisted of twenty one outputs that controlled the parameters of the hand, six output neurons for controlling the upper parts, two for each flexor/extensor pair of each joint of the fingers, two for the global force level of all fingers, and one remaining variable for imposing the degree to which either the global or local force level should influence the motion of the manipulator (Fig. 2).

Notice that the role of the scaling factor (single output of the final network in Fig 2) is to weight the local force levels that are applied to all joints. The Ia boxes in the figure correspond to the flexor/extensor pairs. As shown, two outputs from the network input to each of these boxes that process the positive (extensor) and negative (flexor) forces for the arm. The role of Ia, is to sum these two values and output the result, which acts as the local force that is applied to a joint. The final control for each joint is the sum of the scaled local and global force levels, as illustrated in eq. 9, and depicted in Fig. 2. For this simple task, we defined the relation between global and local force level as a percentage,

according to eq. 3.

For example, for the control of the lower-finger joint, the equation used in our experiments is described below:

$$R_{ii} = O_{13} \quad (9)$$

$$J_4 = R_{ii} * (O_7 - O_8) + (1 - R_{ii}) * (O_{14} - O_{15})$$

where J_4 corresponds to the force that will be applied to the lower joint of the index finger, R_{ii} is the Local force weight, specified implicitly by the network, and O_i correspond to the outputs of the spinal cord module (final Neural Network in our computational model).

As shown from the above, due to the design of the hand constraint methodology, the model is able to cope with lower resolution tasks (by setting the local force parameter R_{ii} to a low value), as well as tasks that require a high degree of detail. Even though none other specification was defined, such as information on the object or the hand configuration, our results indicate that the model is sufficient to facilitate appropriate postures of various grasp types. In our experiments, the degree of detail (i.e. the scaling between local and global level control) to which the joints will be controlled is left as an open parameter specified by the network, but it can also be set empirically, e.g. based on the experience of the robot in the performing task, or by feedback acquired during imitation.

Two different sets of experiments were performed. The first focused on simple grasping tasks, and evaluated the performance of the constraint model on two grasp postures, a power grab and a precision grip. By definition a power grab requires the palm and fingers to achieve maximum contact with the object, and is applicable to large items that are resilient to rough manipulation. In contrast, a precision grip requires a sub-group of the fingers (commonly the thumb and index) to touch the object, and carefully form a posture that will allow a gentle manipulation. Therefore, to evaluate these two grasp types, we isolated the motion control only to the finger joints (by disregarding the elbow and shoulder output units in the network), and predefined a standard posture for the upper hand parts, in order to keep

the palm in close distance to the object. Fig 3 illustrates this standard posture that was used for the grasping experiments.

The second type of experiments was concerned with evaluating the constraint model during both reaching and grasping. The main challenge in this second trial is that the grasp posture should form appropriately during the whole motion, without relying on the sensory information, which is unavailable before contact with the object. As we will demonstrate, our model adapted a strategy of forming a correct posture even before contacting the object. The same effect has been shown to occur in primate species [8], and is the result of the brain attempting to simplify the task in hand.

VI. RESULTS

Based on the two experiments described above we conducted a number of replications, in order to evaluate the performance of the robot. We focused mainly on two issues, the performance of the hand to the task and the implicit adjustment of the R_{li} parameter by the network. All experiments were evaluated based on the ability of the robot to touch the object of the task appropriately, based on the grasp type.

As mentioned the first set of experiments was concerned with testing the ability of the constraint model to form appropriate grasping postures against the object present, and therefore maximize contact. Since the joints corresponding to the shoulder and elbow were kept immobile, the output that referred to these parts was disregarded, while the fitness function of the F4 region (in eq. 5) was not considered during the evolutionary selection.

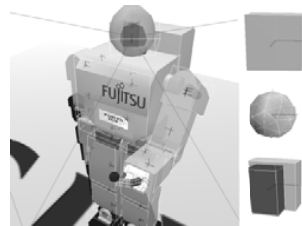

Fig. 3. The graphic output of the simulator during the first set of experiments (left) and the three objects that we used (right).

Three objects were used, namely a sphere, a box and a complex shape, as manipulation objects (Fig 3). The selection of objects was not random since each one's contour possesses some interesting properties for the two grasp types. For example in order to maximize contact with the sphere, the robot should form appropriately all joints in the fingers, to have a 45° angle. In contrast to grab the box, due to the object's placement, the robot should close only the two lower parts of the fingers. Finally for maximizing contact with the complex object (the 3rd object in Fig. 3) the robot should close the lower parts of the fingers 35° and the upper parts for approximately 50° .

In respect to the model, the main difference between these

tasks is depicted on the robot having to form more appropriately its fingers to grab the complex object, i.e. proceed to some individual motion of the upper parts of its fingers. In contrast, adequate grabbing of the ball and box does not require a large degree of variability, and can be performed consistently using a low local force level.

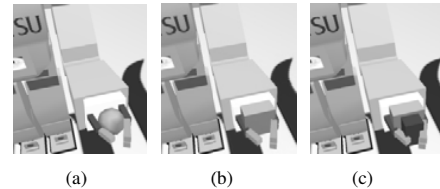

Fig. 4. The optimal individuals of the controller, while grabbing the sphere (a), a box (b) and a complex shape consisting of two boxes (c).

Similarly to biological studies [7, 11] our results indicate that the controller adopted a strategy of simplifying as possible the task that was being performed. This is evident in most of the populations, where the local force level was set by the computational model to a low value. We consider this as an emergent property of the system that is due to the cooperation between the constraint and computational models. For the first two tasks, where the robot was asked to grab the sphere and the box, maximum performance was achieved on an average 0.001 local force level (Fig. 5). This indicates that on most of its part, the robot was able to perform the action simply by applying a force that was the same for all joints. The chart below illustrates the value of the local force level that was output from the network (single neuron in Fig. 2), during the grab sphere experiment, for the 91 individuals of the fittest population. This value is obtained for each individual, by summing over all consequent time steps of a task, and normalizing the result. As mentioned this parameter acts as a scaling factor for the final result, and corresponds to the R_{li} variable of eq. 9.

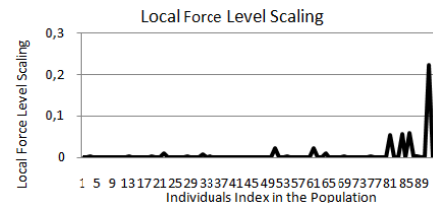

Fig. 5. The averaged over all time steps local force level that was set by the computational model, while grasping the sphere using a power grab, for each of the 91 individuals of the population in the experiment.

It is evident from Fig. 5 that most of the individuals chose to apply a small local force level (i.e. small degree of finger individuation). Individuals 78-91 also choose to apply a local force, and still manage to obtain good results. Nonetheless, the vast majority of the individuals show a clear preference of completing the task with the least complexity possible. We note here that we did not include the number of joints that can be controlled in our fitness functions, which adds more importance to this outcome,

since the controller didn't penalize any individual control of the fingers. This means that our evolutionary model wasn't biased to set the global force parameter at a high value. This was an emergent property of our system which indicates that the model, on its own, chose to adopt the simplest solution. As mentioned during the introduction, this property is also found in some primates during the control of their hand. More importantly, our results indicate that reducing the complexity of control, by using the same force for all fingers, didn't compromise the optimality of the final result. This is evident on the following graph that illustrates the fitness of the individuals in the same experiment as in Fig. 5 (i.e. power grab of a sphere), and shows the overall contact for each individual. Each task consisted of 110 time steps, and therefore, the fit individuals should grab the object for approximately 100 steps (10 steps correspond to the minimum time that is required for the fingers to reach the object). As shown in Fig. 6, the same individuals that employed a small local force for the simple task of grabbing a sphere in Fig. 5 also achieved a very good performance.

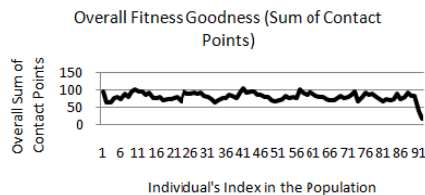

Fig. 6. The fitness function evaluation for the power grab of the sphere.

For the complex object that consisted of the two boxes attached to each other, the average global force level was somewhat higher, ranging from 1%-10% (i.e. 0.01-0.1) on different replications of the experiment. This is also evidence of the constraint model being adequate to perform power grab of more complex objects, using the least complexity possible, where in the case of a more complex object, is higher. As showing in Fig. 3, the complex object consists of two boxes attached to each other. Therefore, ideally, for the hand to maximize contact with this item, it should control at some extent the upper parts of the fingers individually. This results in the model having to set the appropriate local force level to a somewhat higher value than before. Our model was able to resolve that resolution intrinsically, through the interaction with the object. The following graph depicts the changes in the global force parameter during the consequent time steps, for the 91 individuals of the population that were used in the grasping of the complex object experiment.

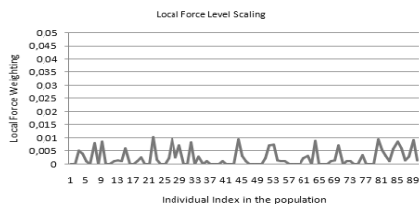

Fig. 7. The local force level, averaged over all time steps, while grabbing the complex object, for each of the 91 individuals in the experiment

It is evident from Fig. 7, that during this experiment, more individuals required a slight higher degree of finger individuation in order to achieve an optimal performance. Nonetheless, performance on the task wasn't compromised, since most of the individuals performed optimally. The following graph (Fig. 8) illustrates the number of time steps that the 91 individuals of the "grab complex object" experiment in Fig. 7 were in contact with the item. The overall time steps for this task were also set to 110, while approximately 10 steps should intervene before the fingers reached the object.

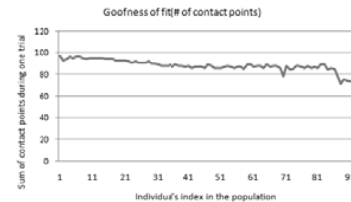

Fig. 8. The evaluation of grabbing for the complex object.

The second trial of experiments evaluated the precision grip grasp. Our fitness function therefore was set to the one in equation eq. 7, penalizing the individuals that used the lower parts of the fingers of the robot, while benefitting those that employed only the higher parts. Ideally, to perform optimally during this experiment the model should set the local force level to a very high value, in order to permit individual motion of only the higher parts of the fingers. In general an average of 70% of the motion was performed by controlling each finger individually. This outcome is also in accordance to the previous experiments that indicate the controller using the least complexity possible. However in contrast to the previous experiments, the task here was obviously more complex, and therefore the controller identified emergently that more fine-tuning initiatives of specific body parts (i.e. the upper finger parts) should be taken to increase task performance. We also notice here that there was none specification on the resolution level that should be used, in the fitness functions of the experiment. Essentially our model was able to implicitly resolve that a higher degree of finger individuation should be used in order to achieve an optimal result for the specific task.

Finally, we evaluated our model during combined reaching and grasping tasks. For these experiments we also activated the fitness function in eq. 5, which corresponded to reaching. Our results indicate that the controller managed to form appropriately its fingers in order to maximize the contact with the object, even though in these experiments the feedback from the touch sensors was unavailable, while reaching, i.e. on most of the time steps of the motion (Fig. 9). Also consistent with biological studies [8] is the property exhibit by the model, of the grasp posture forming long before initiating contact with the object, which is evident on the plot in Fig. 9a, that shows the number of time steps that the grip of the robot wasn't touching the object (overall task duration was 110 time steps as before).

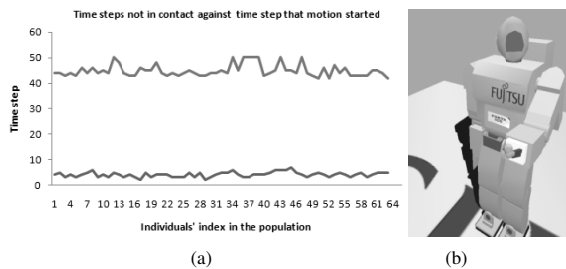

Fig. 9. (Left) The average number of time steps, that the grip remained with no contact is shown on the upper line, the first time step that fingers started moving is shown on the lower line. (Right) Graphic output of our simulator after the robot grasped the item.

As the graph above illustrates the number of time steps that the grip wasn't in contact with the final object was ranging from 40 to 50 steps. However, the grip starting forming long before contact, roughly at the 5th time step, for each of the 64 individuals in the population, which is shown in the lower line in Fig. 9a. This outcome is in accordance to neurobiological studies that indicate the pre-shaping of the hand, using a common to all joints force, during the first levels of the motion [7]. The corresponding output of the simulator, at the end of the reaching sub-task and after initiating contact with the object is shown in Fig. 7.b.

VII. DISCUSSION

Reaching to grasp tasks have been long considered as an interesting problem by the computational modelling society due to the high dimensionality imposed by the large number of joints in the hand. Other attempts to confront the issue have either relied on constraining the task to be executed, or constraining the articulator to empirically pre-defined combinations of joints. In this study we presented a model that does not make any compromises on either the task in hand, the structure of the articulator or the type of grasps it can support. In contrast, it includes a constraint model, based on biologically inspired kinematic coordination patterns that are controlled by the underlying computational process, and are common to all tasks. The strength of the methodology lies in enabling the computational model to decide on the difficulty of the task and the appropriate level of resolution that it should follow. In more complicated tasks, where fingers should form in isolation, the computational model has been proven adequate to adjust the inline resolution factor, in order to individuate the motion of appropriate fingers. The design mechanism employed for developing the computational process consisted of a co-evolutionary scheme that has been shown to obtain a high performance when coordinating a large number of Networks. The biological inspiration of the paper lies in the design of the motor related areas, which were evolved to apply different resolution levels of control for the same task, as well as the design of the constraint methodology. The performance of the model was evaluated against both simple and complex tasks. Results indicate that several biologically equivalent

properties have emerged, without us specifying them on the fitness functions. For example, the controller uses the least possible complexity to achieve optimal results. More importantly our model has demonstrated very good performance on the variety of tasks that it was tested. Another important factor of the research was that grasp postures were formed solely based on the interaction with the object, without providing any information regarding the object contour.

In the future we plan to integrate both the computational and constraint models to a real robot, in order to study the complications of grasping in real world conditions. In addition we will extend these experiments to enable the robot imitate, by including imitation related areas in our brain counterpart.

VIII. REFERENCES

- [1] A. H. Fagg and M. A. Arbib, "Modeling parietal-premotor interactions in primate control of grasping," *Neural Networks*, vol. 11, pp. 1277-1303, 1998.
- [2] E. Oztop and M. A. Arbib, "Schema design and implementation of the grasp-related mirror neuron system," *Biological Cybernetics*, vol. 87, pp. 116-140, 2002.
- [3] M. I. Kuniyoshi, Y. Yorozu, M. Inaba, and H. Inoue, "From visuo-motor self learning to early imitation - A neural architecture for humanoid learning," in *Proceedings of the 2003 IEEE International Conference on Robotics and Automation*, Taipei, Taiwan, 2003.
- [4] Y. Kuniyoshi, M. Inaba, and H. Inoue, "Learning by watching: Extracting reusable task knowledge from visual observation of human performance," in *IEEE Transactions on Robotics and Automation*, 1994, pp. 799-822.
- [5] G. Rizzolatti, L. Fadiga, V. Gallese, and L. Fogassi, "Premotor cortex and the recognition of motor actions," *Cognitive Brain Research*, vol. 3, pp. 131-141, 1996.
- [6] H. E. Savaki, V. Raos, and M. N. Evangelou, "Observation of action: grasping with the mind's hand in *Neuroimage*, 2004. vol. 23, 2004, pp. 193-201.
- [7] M. H. Schieber and M. Santello, "Hand function: peripheral and central constraints on performance," *Journal of Applied Neurophysiology*, pp. 2293-2300, 2004.
- [8] C. R. Mason, L. S. Theverapperuma, C. M. Hendrix, and T. J. Ebner, "Monkey Hand Postural Synergies During Reach-To-Grasp in the Absence of Vision of the Hand and the Object," *Journal of Neurophysiology*, vol. 91, pp. 2826-2837, 2004.
- [9] J. R. Napier, "The prehensile movements of the human hand," *Journal of Bone and Joint Surgery Br*, vol. 38, pp. 902-913, 1956.
- [10] M. A. Arbib and T. Iberall, "Schemas for the control of hand movements: An essay on cortical localization," in *The control of grasping*, M. Goodale, Ed. Ablex Norwood, 1990, pp. 163-180.
- [11] M. Santello and J. F. Soechting, "Gradual modding of the hand to object contours," *Journal of Neurophysiology*, vol. 79, pp. 1307-1320, 1998.
- [12] M. J. Mataric and A. Billard, "A Biologically Inspired Robotic Model for Learning by Imitation," in *Proceedings of the Fourth International Conference on Autonomous Agents*, 2000, pp. 373-380.
- [13] M. Maniadakis, E. Hourdakias, and P. Trahanias, "Modelling overlapping execution/observation pathways," in *International Joint Conference on Neural Networks*, Florida, 2007.
- [14] M. Maniadakis and P. Trahanias, "Modelling brain emergent behaviors through coevolution of neural agents," *Neural Networks*, vol. 19, pp. 705-720, 2006.